



**Advanced Performance. Total Reliability.**

**Owner's Manual**  
For professional use only

Do not use this equipment  
before reading this manual!

# **SPEEFLO Hydra Pro IV™**

## **Gas Powered Airless Sprayer**

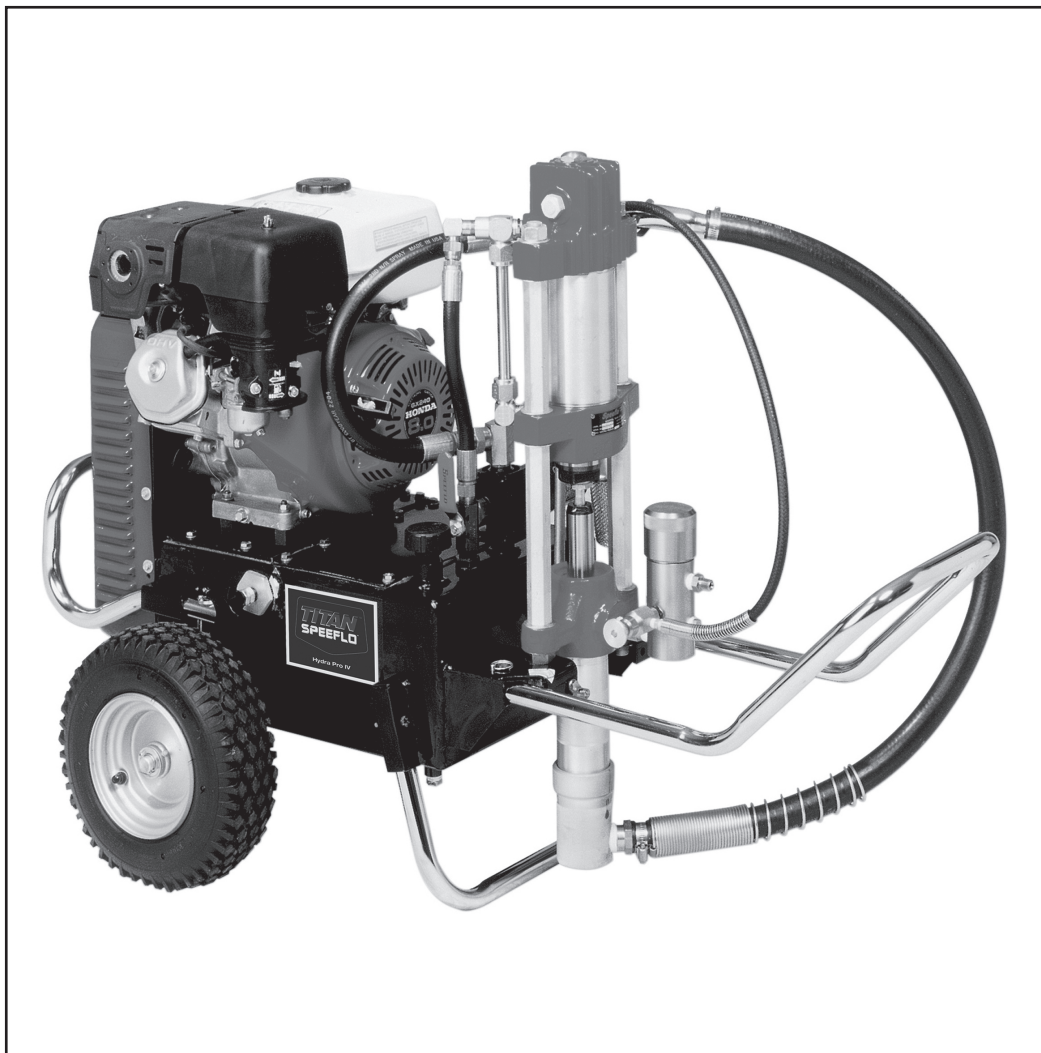

**Model Numbers:**

**433-820**

**433-821**

**NOTE:** This manual contains important warnings and instructions. Please read and retain for reference.



## Important Safety Information • Read all safety information before operating the equipment. **SAVE THESE INSTRUCTIONS.**



This symbol indicates a hazardous situation, which, if not not avoided could result in death or serious injury.



To reduce the risks of fire or explosion, electrical shock, and the injury to persons, read and understand all instructions included in this manual. Be familiar with the controls and the proper usage of the equipment.



**WARNING – To reduce the risk of fire or explosion:**



1. Do not spray flammable or combustible materials near an open flame, pilot lights or sources of ignition such as hot objects, cigarettes, motors, electrical equipment and electrical appliances. Avoid creating sparks from connecting and disconnecting power cords.
2. For units intended for use with only water-based materials — Do not spray or clean with flammable liquids. For use with water-based liquids only.
3. For units intended for use with only water-based or mineral spirit-type materials with a minimum flash point of 21°C (69.8°F) — Do not spray or clean with liquids having a flash point of less than 21°C (69.8°F). Flash point is the temperature at which a fluid can produce enough vapor to ignite.
4. Paint or solvent flowing through the equipment is able to result in static electricity. Static electricity creates a risk of fire or explosion in the presence of paint or solvent fumes. All parts of the spray system, including the pump, hose assembly, spray gun and objects in and around the spray area shall be properly grounded to protect against static discharge and sparks. Use only conductive or grounded high-pressure airless paint sprayer hoses specified by the manufacturer.
5. Verify that all containers and collection systems are grounded to prevent static discharge.
6. Connect to a grounded outlet and use grounded extension cords (electric models only). Do not use a 3 to 2 adapter.
7. Do not use a paint or solvent containing halogenated hydrocarbons. Such as chlorine, bleach mildewcide, methylene chloride and trichloroethane. They are not compatible with aluminum. Contact the coating supplier about compatibility of material with aluminum.
8. Keep spray area well ventilated. Keep a good supply of fresh air moving through the area to keep the air within the spray area free from accumulation of flammable vapors. Keep pump assembly in well ventilated area. Do not spray pump assembly.
9. Do not smoke in the spray area.
10. Do not operate light switches, engines, or similar spark producing products in the spray area.
11. Keep area clean and free of paint or solvent containers, rags, and other flammable materials.
12. Know the contents of the paint and solvents being sprayed. Read all Material Safety Data Sheets (MSDS) and container labels provided with the paints and solvents. Follow the paint and solvent manufacture's safety instructions.
13. Place pump at least 25 feet (7.62 meters) from the spray object in a well ventilated area (add more hose if necessary). Flammable vapors are often heavier than air. Floor area must be extremely well ventilated. The pump contains arcing parts that emit sparks and can ignite vapors.

14. Plastic can cause static sparks. Never hang plastic to enclose spray area. Do not use plastic drop cloths when spraying flammable material.
15. Fire extinguisher equipment shall be present and working.



**WARNING – To reduce the risk of skin injection:**



### HAZARD:

**Injection injury – A high pressure fluid stream produced by this equipment can pierce the skin and underlying tissues, leading to a serious injury and possible amputation. See a physician immediately. DO NOT TREAT AN INJECTION AS A SIMPLE CUT.**

1. Do not aim the gun at, or spray any person or animal.
2. Keep hands and other body parts away from the discharge. For example, do not try to stop leaks with any part of the body.
3. Always use the nozzle tip guard. Do not spray without the nozzle tip guard in place.
4. Only use a nozzle tip specified by the manufacturer.
5. Use caution when cleaning and changing nozzle tips. In the case where the nozzle tip clogs while spraying, ALWAYS lock gun trigger, shut pump off, and release all pressure before servicing, cleaning tip or guard, or changing tip. Pressure will not be released by turning off the motor. The PRIME/SPRAY valve or pressure bleed valve must be turned to their appropriate positions to relieve system pressure. Refer to PRESSURE RELIEF PROCEDURE described in the pump manual.
6. Do not leave the unit energized or under pressure while unattended. When the unit is not in use, turn off the unit and relieve the pressure in accordance with the manufacturer's instructions.
7. High-pressure spray is able to inject toxins into the body and cause serious bodily injury. In the event that injection occurs, seek medical attention immediately.
8. Check hoses and parts for signs of damage, a leak can inject material into the skin. Inspect hose before each use. Replace any damaged hoses or parts.
9. This system is capable of producing 3300 PSI / 22.8 MPa. Only use replacement parts or accessories that are specified by the manufacturer and that are rated a minimum of 3300 PSI. This includes spray tips, nozzle guards, guns, extensions, fittings, and hose.
10. Always engage the trigger lock when not spraying. Verify the trigger lock is functioning properly.
11. Verify that all connections are secure before operating the unit.
12. Know how to stop the unit and bleed pressure quickly. Be thoroughly familiar with the controls. Pressure will not be released by turning off the motor. The PRIME/SPRAY valve or pressure bleed valve must be turned to their appropriate positions to relieve system pressure. Refer to PRESSURE RELIEF PROCEDURE described in the pump manual.
13. Always remove the spray tip before flushing or cleaning the system.



# Important Safety Information • Read all safety information before operating the equipment. SAVE THESE INSTRUCTIONS.



## WARNING – To reduce the risk of injury:

1. Always wear appropriate gloves, eye protection, clothing and a respirator or mask when painting. Hazardous vapors – Paints, solvents, insecticides, and other materials can be harmful if inhaled or come in contact with body. Vapors can cause severe nausea, fainting or poisoning.
2. Do not operate or spray near children. Keep children away from equipment at all times.
3. Do not overreach or stand on an unstable support. Keep effective footing and balance at all times.
4. Stay alert and watch what you are doing.
5. Do not operate the unit when fatigued or under the influence of drugs or alcohol.
6. Do not kink or over-bend the hose. Airless hose can develop leaks from wear, kinking and abuse. A leak can inject material into the skin.
7. Do not expose the hose to temperatures or pressures in excess of those specified by manufacturer.
8. Do not use the hose as a strength member to pull or lift the equipment.
9. Use lowest possible pressure to flush equipment.
10. Follow all appropriate local, state and national codes governing ventilation, fire prevention and operation.
11. The United States Government Safety Standards have been adopted under the Occupational Safety and Health Act (OSHA). These standards, particularly part 1910 of the General Standards and part 1926 of the Construction Standards should be consulted.
12. Before each use, check all hoses for cuts, leaks, abrasion or bulging of cover. Check for damage or movement of couplings. Immediately replace hose if any of those conditions exist. Never repair a paint hose. Replace with a conductive high-pressure hose.
13. Do not spray outdoors on windy days.
14. Always unplug cord from outlet before working on equipment (electric models only).

## Grounding Instructions

Electric models must be grounded. In the event of an electrical short circuit, grounding reduces the risk of electric shock by providing an escape wire for the electric current. This product is equipped with a cord having a grounding wire with an appropriate grounding plug. The plug must be plugged into an outlet that is properly installed and grounded in accordance with all local codes and ordinances.

**WARNING** — Improper installation of the grounding plug can result in a risk of electric shock. If repair or replacement of the cord or plug is necessary, do not connect the green grounding wire to either flat blade terminal. The wire with insulation having a green outer surface with or without yellow stripes is the grounding wire and must be connected to the grounding pin.

Check with a qualified electrician or serviceman if the grounding instructions are not completely understood, or if you are in doubt as to whether the product is properly grounded. Do not modify the plug provided. If the plug will not fit the outlet, have the proper outlet installed by a qualified electrician.

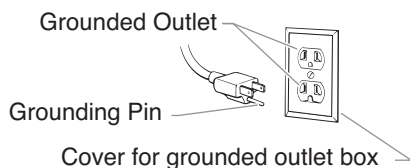

**IMPORTANT:** Use only a 3-wire extension cord that has a 3-blade grounding plug and a 3-slot receptacle that will accept the plug on the product. Make sure your extension cord is in good condition. When using an extension cord, be sure to use one heavy enough to carry the current your product will draw. An undersized cord will cause a drop in line voltage resulting in loss of power and overheating. A 12 gauge cord is recommended. If an extension cord is to be used outdoors, it must be marked with the suffix W-A after the cord type designation. For example, a designation of SJTW-A would indicate that the cord would be appropriate for outdoor use.

## Gasoline Engine Safety



**The engine exhaust from this unit contains chemicals known to the State of California to cause cancer, birth defects, or other reproductive harm.**

1. Gas engines are designed to give safe and dependable service if operated according to instructions. Read and understand the engine Owner's Manual before operating the engine. Failure to do so could result in personal injury or equipment damage.
2. To prevent fire hazards and to provide adequate ventilation, keep the engine at least 1 meter (3 feet) away from buildings and other equipment during operation. Do not place flammable objects close to the engine.
3. Children and pets must be kept away from the area of operation due to a possibility of burns from hot engine components or injury from any equipment the engine may be used to operate.
4. Know how to stop the engine quickly, and understand the operation of all controls. Never permit anyone to operate the engine without proper instructions.
5. Gasoline is extremely flammable and is explosive under certain conditions.
6. Refuel in a well-ventilated area with the engine stopped. Do not smoke or allow flames or sparks in the refueling area or where gasoline is stored.
7. Do not overfill the fuel tank. After refueling, make sure the tank cap is closed properly and securely.
8. Be careful not to spill fuel when refueling. Fuel vapor or spilled fuel may ignite. If any fuel is spilled, make sure the area is dry before starting the engine.
9. Never run the engine in an enclosed or confined area. Exhaust contains poisonous carbon monoxide gas; exposure may cause loss of consciousness and may lead to death.
10. The muffler becomes very hot during operation and remains hot for a while after stopping the engine. Be careful not to touch the muffler while it is hot. To avoid severe burns or fire hazards, let the engine cool before transporting it or storing it indoors.
11. Never ship/transport unit with gasoline in the tank.



**DO NOT use this equipment to spray water or acid.**

**IMPORTANT:** Do not lift by cart handle when loading or unloading.

## Warning Labels

Your sprayer has the English language warning labels. If you require these labels in French, German, or Spanish, or require additional English labels, order directly from Titan free of charge.

Part #	Language
745-056	English
745-057	Spanish
745-058	French
745-059	German

## Table of Contents

<b>Safety Precautions</b> .....	<b>2</b>
Grounding Instructions .....	3
<b>Specifications</b> .....	<b>4</b>
<b>Introduction</b> .....	<b>4</b>
<b>Setup</b> .....	<b>6</b>
Fueling (gas engine).....	6
<b>Operation</b> .....	<b>7</b>
Startup .....	7
Pressure Relief Procedure .....	7
Cleaning a Clogged Tip.....	8
Color Change / Clean Out.....	8
<b>Maintenance</b> .....	<b>8</b>
Hydraulic System .....	8
General Fluid Pump Maintenance.....	8
Basic Engine Maintenance.....	9
<b>Troubleshooting</b> .....	<b>10</b>
Airless Spraying .....	10
Spray Patterns.....	11
Hydraulic Motors .....	12
Fluid Sections.....	13
<b>Parts Lists and Service Instructions</b> .....	<b>14</b>
Hydra Pro IV Major Components .....	14
Engine Drive & Hydraulic System .....	16
Tank Assembly and Mobil Kit.....	18
Hydraulic motor, 441-574.....	20
Fluid Pump, 185-551.....	24
Fluid Accessories .....	26
Outlet Accessories .....	27
<b>Accessories and Service Kits</b> .....	<b>29</b>
<b>Warranty</b> .....	<b>32</b>

## Specifications

Gallons per minute (GPM).....	2.5
Cycle rate per gallon.....	20
Cycles per minute (max).....	50
Maximum tip size:	
1-Gun.....	.050"
2-Gun.....	.035"
3-Gun.....	.029"
Pressure range .....	500-3300 psi
Power .....	8.0 HP Honda engine, electric start
Fuel capacity .....	1.4 gallons
Halogenated solvent compatible ...	Yes
Weight .....	349 lbs
Inlet paint filter .....	"Rock catcher"
Outlet paint filter .....	50 mesh, 18in <sup>2</sup>
Pump inlet.....	1" NPT (F)
Pump outlet .....	1/2" NPT(F) to paint filter
Paint filter hose connections.....	(1) - 1/4" NPSM(M) (1) 3/8" NPT(F) Plugged
Dimensions.....	36 1/2" H x 51" L w/handle (38" w/o handle) x 24 1/2" W

### Fluid Pump Wetted Parts:

Cadmium plated ductile iron, electroless nickel plated carbon steel, hard chrome anti-wear surface, stainless steel, tungsten carbide, thiokol impregnated leather, ultra high molecular weight polyethylene.

## Introduction

Congratulations on having selected the finest airless sprayer available in the world. Titan piston pumps are tireless workhorses - so tough they are virtually indestructable, even under the most severe service.

Titan designs and builds equipment with superior quality and reliability. Equipment that will last for years with minimal maintenance and downtime. This equipment will make you money year after year. We thank you for your purchase and welcome you to our large and growing family of Titan users.

Hydraulic drive makes possible the longest stroke and slowest cycling pumps in the industry which translates into low maintenance and longer life.

The Hydra Pro IV™ is equipped with Titan's exclusive and patented Severe Service™ fluid pump. This technology will give you significantly longer rod, cylinder, and packing life than any other sprayer built in the world. This double ball piston pump employs a dependable and durable time-tested design. All pumps use an exclusive thick hard chrome plating on rod and cylinder parts. This patented plating process is harder than nitralloy, stainless steel, or hard chrome used by any other paint pump manufacturer and much more abrasion resistant. Highly polished parts reduce friction, extend packign life, and avoid damage from corrosion and abrasion. Simply stated - this is the world's best paint pump.

The Hydra Pro IV™ offers other cost saving features:

- Variable pressure control from 500 to 3300 psi
- Very large tungsten carbide valve seats with hardened stainless steel balls
- Self-adjusting packings
- Exclusive hand-tight swivel foot valve
- Large capacity inline paint filter
- "Floating ball" pressure bleed valve
- 5 gallon siphon hose and bleed line assemblies are standard

You have made an excellent choice. We know you will be pleased with your new Hydra Pro IV™ airless sprayer. We appreciate your business.

# Hydra Pro IV™

## Run Position

When the handle is in this position, the system is pressurized. Use extreme caution. Follow all warnings and instructions regarding pressure relief procedure

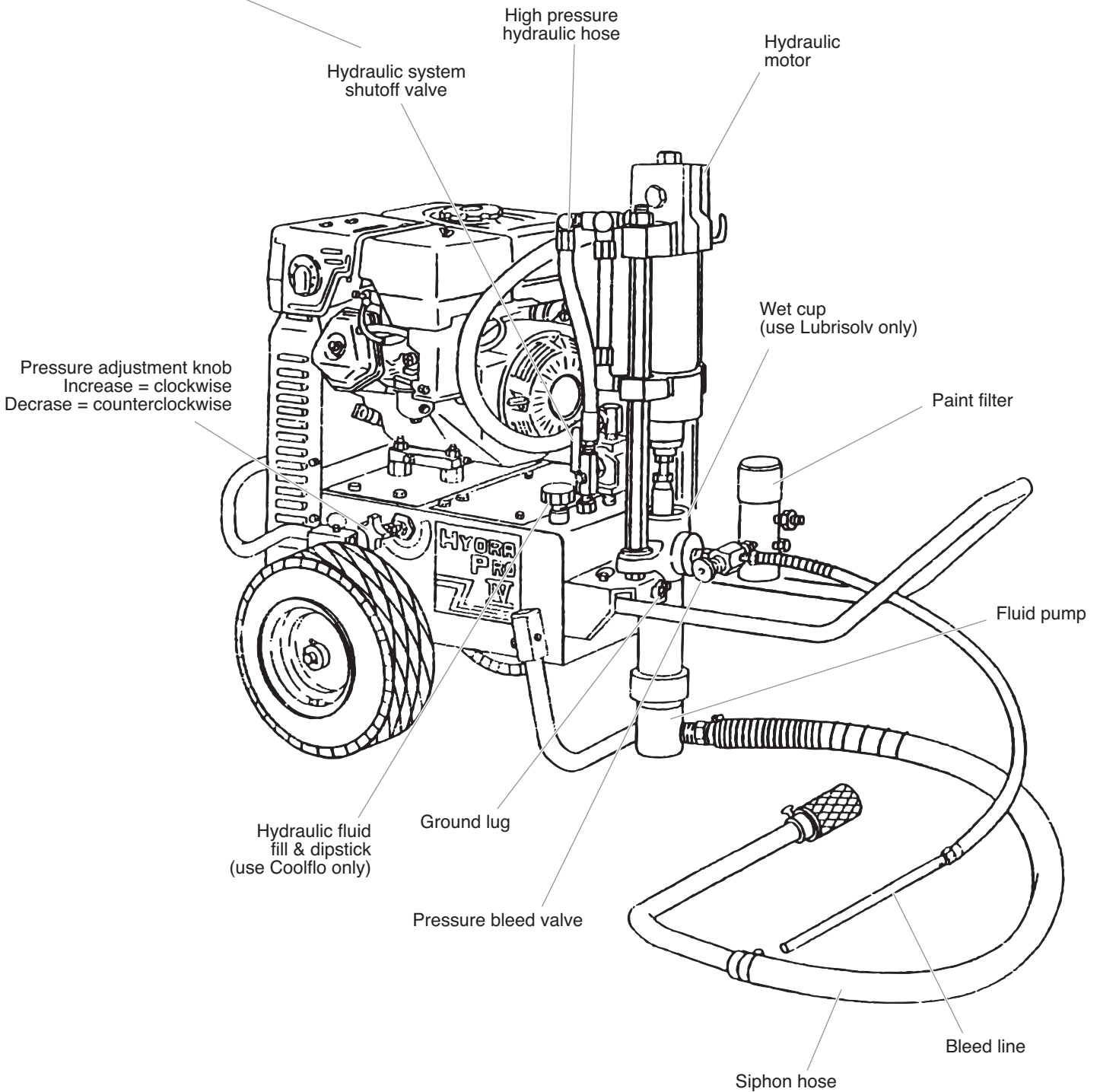

## Setup



Read, understand, and follow all warnings before starting or operating this sprayer.

Required tools: Adjustable wrench

### 1. Connecting the hoses:

The siphon hose and bleed line hose have factory installed PTFE tape on the male end of the hoses. Tighten the siphon hose and bleed line wrench tight.

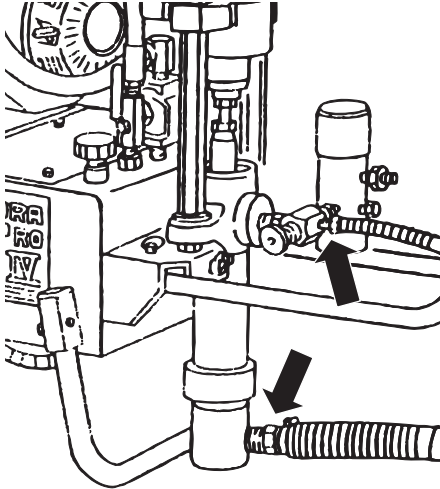

### 2. One gun operation:

Attach the gun and hose. Always use a spray hose at least 50 feet long. Do not use PTFE or thread sealant on this assembly. Do not install the spray tip at this time.

### 3. Two gun operation:

Remove the plug from the second gun outlet. Replace with nipple, part # 812-003 for 1/4" hose or nipple; use part # 808-555 for 3/8" hose. Connect a hose and a gun to the outlet.

### 4. Multiple gun operation:

The Hydra Pro IV™ is engineered to handle up to 4 guns. When using more than two guns, make sure the second gun hookup outlet is plugged. Connect the multiple gun manifold to the single gun outlet. These manifolds are for either 2, 3, or 4 guns and have shutoff valves. Connect a hose and gun to each outlet.

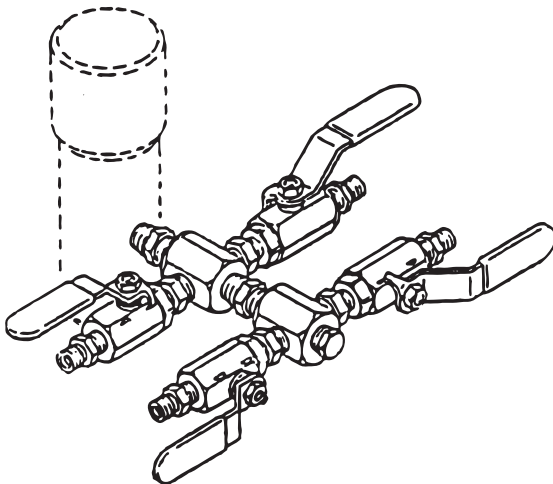

5. Fill the wet-cup 1/2 full with Titan's Piston Lube, part # 314-480 supplied by the factory. This extends packing life.

6. Be sure the Hydra Pro IV™ system is grounded. All Titan units are equipped with a grounding lug. A grounding cable (not supplied) should be used to connect the unit to a true earth ground. Check your local electrical regulations for detailed grounding instructions.



Proper grounding is important. This applies to both gas and electric powered models. The passage of some materials through the nylon fluid hose will build up a static electric charge, which if discharged, could ignite solvent vapors present and create an explosion.

7. Strain all paints to assure trouble-free operation and freedom from frequent cleaning of inlet screen and gun strainer.

## Fueling (gas engine)



Gasoline is extremely flammable and is explosive under certain conditions.

- ALWAYS turn the engine off before refueling.
- Refuel in a well-ventilated area.
- Do not smoke or allow flames or sparks in the refueling area or where gasoline is stored.
- Do not overfill the fuel tank. After refueling, make sure the tank cap is closed properly and securely.
- Be careful not to spill fuel when refueling. Spilled fuel or fuel vapor may ignite. If any fuel is spilled, make sure the area is dry before starting the engine.
- Avoid repeated or prolonged contact with skin or breathing of vapor.
- Keep out of the reach of children.

## Fuel Specifications

- Use automotive gasoline that has a pump octane number of 87 or higher, or that has a research octane number of 91 or higher. Use of a lower octane gasoline can cause persistent "pinging" or heavy "spark knock" (a metallic rapping noise) which, if severe, can lead to engine damage.

**NOTE:** If "spark knock" or "pinging" occurs at a steady engine speed under normal load, change brands of gasoline. If spark knock or pinging persists, consult an authorized dealer of the engine manufacturer. Failure to do so is considered misuse, and damage caused by misuse is not covered by the engine manufacturer's limited warranty.

Occasionally you may experience light spark knock while operating under heavy loads. This is no cause for concern, it simply means your engine is operating efficiently.

- Unleaded fuel produces fewer engine and spark plug deposits and extends the life of the exhaust system components.
- Never use stale or contaminated gasoline or an oil/gasoline mixture. Avoid getting dirt, dust, or water in the fuel tank.

# Operation

## Startup

1. Areas must be well-ventilated to prevent hazardous operation with volatile solvents or exhaust fumes.



**If lacquer or other flammable materials are to be sprayed, ALWAYS locate the unit outside the immediate spraying area. Failure to do so may cause an explosion.**

2. Locate the unit outside the immediate spraying area to avoid clogged air intake of the engine or electric motor with overspray.
3. **Before starting the unit**, check oil levels:
  - a. The hydraulic fluid level should read "Full" on the dipstick. Check it daily. See the hydraulic system maintenance instructions for changing or adding hydraulic fluid. Do not overfill. Use only Titan Coolflo™, part no. 430-361.
  - b. The gasoline engine oil level is determined by the manufacturer. Check the manufacturer's service manual supplied.
4. Open the orange handle shut-off valve located on the hydraulic return hose. Handle should be in line with hose. The figure below shows the handle in the open position.

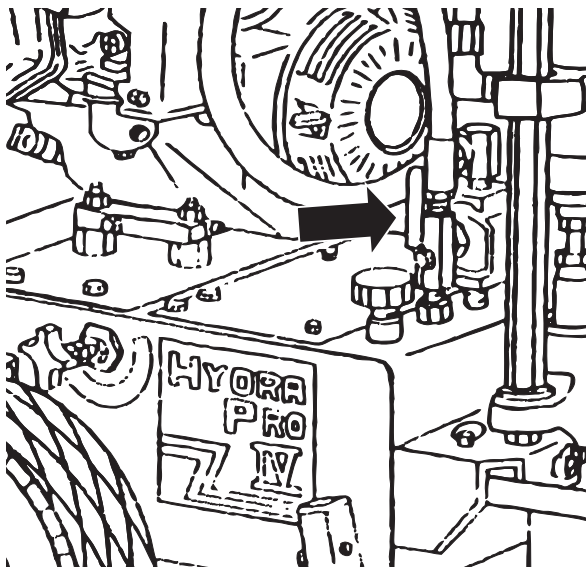

5. Turn the pressure adjustment knob counterclockwise to lowest pressure setting.
6. Open the pressure bleed valve by turning it counterclockwise. This relieves pressure. See figure below.
  - a. Your new sprayer was tested at the factory with water soluble oil. You must clean the system before spraying to avoid contamination of the sprayed material.  
If you are spraying a water-based latex, flush with warm, soapy water followed by a clean water rinse.  
If you are using any other coating, flush with warm, soapy water followed by a solvent. Check with the material manufacturer for a compatible solvent.  
Place siphon tube assembly into proper solvent or water.
  - b. Place waste container below bleed line.
  - c. Start engine. Turn pressure control adjustment knob clockwise (increasing pressure) until pump cycles evenly and solvent flows freely from bleed line.

- d. Close pressure bleed valve by turning it clockwise. This allows the system to pressurize. Hold gun trigger open, without spray tip attached, until the fluid flows smoothly. See figure below.

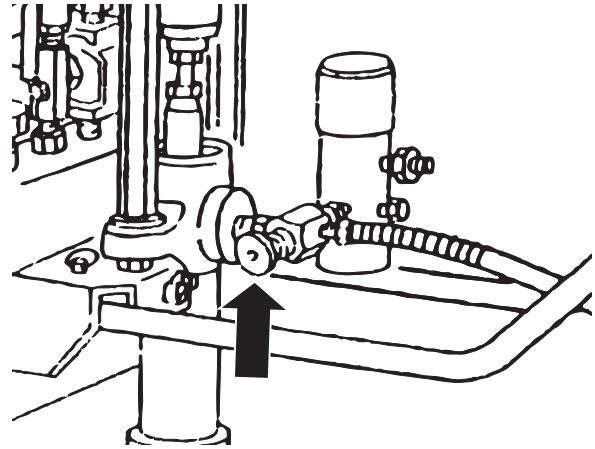

7. Repeat above starting procedure with paint material. Lock gun trigger and attach spray tip. See the Technical Data Sheet or Operator's Manual on the gun provided for installation and selection of the proper tip sizes.
8. Test spray pattern. Operate the pump at the lowest hydraulic pressure which provides good atomization. See the Troubleshooting Guide if you are not getting the proper pattern.
9. Operating pressure is adjustable from 500 to 3300 psi by turning the pressure adjustment knob clockwise. Do not turn the knob clockwise more than necessary to provide satisfactory atomization. Excess pressure wears out spray tips.
10. When restarting the unit, reduce the pressure at pressure control adjustment knob and pressure bleed valve.

## Pressure Relief Procedure

**IMPORTANT: Always reduce pressure when you are cleaning a clogged tip, changing a tip, servicing any part of the system, or shutting down. Follow the steps below.**

1. Engage the gun trigger lock.
2. Shut off the power source.
3. Close the orange handle shut-off ball valve on the hydraulic hose.
4. Open the pressure bleed valve by turning it counterclockwise at least three full turns.
5. Disengage the gun trigger lock and hold trigger open until flow of material stops.
6. Be certain to hold a metal part of the gun firmly to the side of a grounded metal container.

## Cleaning a Clogged Tip

1. Follow the Pressure Relief Procedure, page 7.
2. Lock the gun trigger.
3. Unthread the safety tip guard and remove the spray tip. Wash the tip in solvent and use a tip probe to remove any clogged material.
4. Release the gun trigger lock and spray briefly into a waste container to blow out any clogged particles.
5. Reset the trigger lock in the "Trigger Locked" position. Release the trigger lock and resume spraying.



**The flow from the spray tip is at very high pressure. Contact with any body part may be dangerous. Do not place finger on gun outlet. Do not point the gun at any person. Never operate the spray gun without the proper tip guard.**

## Color Change / Clean Out / Flushing

**IMPORTANT: Use only compatible solvents when cleaning out oil based enamels, lacquers, coal tar, and epoxies. Check with the fluid manufacturer for a recommended solvent.**

1. Reduce pressure by turning the pressure adjustment knob and the pressure bleed valve on the bleed line counterclockwise. Follow the Pressure Relief Procedure, page 7.  
The pressure bleed valve should be turned counterclockwise three full turns.
2. Pull the siphon tube out of the material container.
3. Remove the spray tip from the gun. Hold the gun trigger open until material flow stops.
4. Put siphon tube into wash solvent or water as applicable, and operate pump slowly at low pressure until solvent flows freely from pressure bleed valve line.
5. Close pressure bleed valve and hold gun trigger open until solvent flows freely from gun. If solvent is not too dirty, recirculate it by flowing gun stream back into solvent container. Use additional clean solvent and repeat procedure if necessary.
6. Check gun strainer screen and pump outlet filter screen daily. Use 50 mesh screens with spray tip size .018 and larger. Use 100 or 200 mesh screens with spray tip sizes .015 and smaller.
7. Replace paint filter cap to maximize clockwise rotation. The filter cover should be hand removable after the first or second use with new Teflon O-ring.

**IMPORTANT: O-ring must have PTFE backup washer to seal properly.**

8. If unit has been spraying a water soluble material, flush with water and then repeat procedure with mineral spirits or Varsol solvent.
9. Wash spray tip in solvent. Blow tip clean with air pressure directed through the tip in the reverse direction.

## Maintenance

### Hydraulic System

1. Check the hydraulic fluid daily. It should read "Full" on the dipstick. If it is low, add only Titan Coolflo, part # 430-361. Never add or change hydraulic fluid except in a clean, dust-free environment. Contamination of the hydraulic fluid will shorten hydraulic pump life and may void warranty.

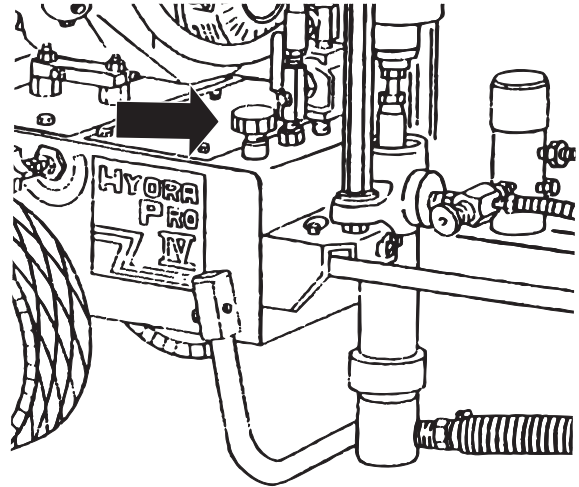

2. Change the hydraulic fluid every six months. Drain old fluid from tank and fill with 5 gallons of Coolflo. Start operation of the system at just enough pressure to operate the fluid pump. Run the system at this low pressure for at least 5 minutes. This removes air from the system. Check the fluid level after this procedure.
3. The hydraulic system has an external replaceable hydraulic filter. Change the filter every six months.
4. The hydraulic pump should not be serviced in the field. If service on the hydraulic pump is required, it must be returned to Titan.

### General Fluid Pump Maintenance

If the paint pump is going to be out of service for an extended period of time, it is recommended that following cleanup a kerosene and oil mixture be introduced as a preservative. Packings may tend to dry out from lack of use. This is particularly true of the upper packing set for which upper packing lubricant, Titan part # 314-480, is recommended in normal usage. A sample of **Piston Lube** accompanies each new unit. Do not substitute water or paint solvent for **Piston Lube**. Ordinary oil may contaminate the paint material and is not recommended.

If the paint pump has been out of service for an extended period of time, it may be necessary to prime the suction by pouring some of the paint solvent into the inlet siphon tube to restart. **It is extremely important that the threads on the inlet siphon hose coupling are properly sealed. Any air leakage will produce erratic operation of pump and may damage the system.** The up and down strokes should be approximately equal in time. That is, one should not be faster than the other. A fast up or down stroke may indicate air in the system or malfunctioning valve or seats. See the Troubleshooting Guide.

### Hydraulic Motor & Fluid Pump Service

See the individual Technical Data Sheets for maintenance and service instructions on the reciprocating hydraulic motor and the fluid pump.



## Basic Engine Maintenance

- For detailed engine maintenance and technical specifications refer to the separate gasoline engine manual.
- All service to the engine should be performed by a dealer authorized by the engine manufacturer. To locate a dealer in your area, look in the Yellow Pages of your telephone directory under Gasoline Engines, Garden & Lawn Equipment & Supplies, Lawn Mowers, etc.
- The gas engine is warranted exclusively by the engine manufacturer.
- Use a premium quality motor oil certified to meet or exceed U.S. Automotive requirement SG.or SF. SAE 10W30 is recommended for general all temperature use. Other viscosities may be required in other climates.
- Use only a (NGK) BP6ES or BPR6E spark plug. Gap the plug to 0.028 to 0.031 In. (0.7 to 0.8 mm) Always use a spark plug wrench.

### Daily

1. Check engine oil level, and fill as necessary.
2. Check gasoline level, and fill as necessary.



**Always follow the fueling procedure outlined earlier in this manual.**

### First 5 Hours

1. Change engine oil.

### Every 25 Hours

1. Change engine oil.

### Weekly

1. Remove the air filter cover and clean the element. In very dusty environments, check the filter daily. Replace the element as needed. Replacement elements can be purchased from your local engine dealer.



## Engine Operation and Service

1. Clean and oil air filter pad on gasoline engine every 25 hours or once weekly. Do not permit the air intake screen around the fly wheel of the gas engine to load up with paint or trash. Clean it regularly. The service life and efficiency of the gas engine model depends upon keeping the gasoline engine running properly. Change the oil in the engine every 100 hours. Failure to observe this may result in engine overheating. Consult the engine manufacturer's service manual provided.
2. To conserve fuel, service life, and efficiency of the sprayer, always operate the gasoline engine at the lowest RPM at which it runs smoothly without laboring and delivers the amount required for the particular painting operation. Higher RPM does not produce higher working pressure. The gasoline engine is connected to the hydraulic pump by a pulley combination designed to produce full paint delivery at maximum RPM.
3. The warranty on gasoline engines or electric motors is limited to the original manufacturer.

## Troubleshooting - Airless Spraying

Condition	Possible Cause	Correction
A. Poor spray pattern and / or tails at top and bottom of the spray pattern.	Worn or incorrect tip and/or insufficient atomization. Hose size or length is too small or too long. Dirty filter.	Be sure the tip is not worn. Increase pressure. Lower viscosity. Reduce surface tension by increasing hose size to minimize pressure drop through hose and/or reduce hose lengths. Use preorifice disc (H disc).
B. The gun drips or throws a drop at the beginning or end of the spray pattern.	Needle may not be seating correctly.  Increase spring tension.	Needle-orifice combination should be factory relapped. Needle packing may be too tight. Loosen as much as possible without leakage.  Turn adjusting screw on back of gun clockwise to increase tension or use the green HP spring Part # 701-098.
C. Spray tip stops up frequently.	Particles too large for spray tip are passing filter and/or gun screen.	Use 100 mesh gun screen instead of 50 mesh for small spray tips. Use 100 mesh screen in pump filter. Strain paint.
D. Spray pattern changes with pump cycle.	Restrictions in the fluid system.	Check gun and pump filter screens. Always clean screens before they load up.
E. Irregular flow of material. One stroke faster than the other.	Packings are worn or valve balls are not seating. Restriction in the siphon system.	Check siphon hose assembly to be sure no air is entering, then recheck all threaded fittings for leakage. See Troubleshooting - Fluid Section for additional service information.
F. Spitting.	Air in system. Dirty gun.	Inspect for siphon hose leak. Disassemble and clean gun.
G. Gun does not spray any fluid.	Suction hose leak. No paint. Plugged foot valve. Plugged filters or tip. Ball check valve stuck open.	Inspect for siphon hose leak. Check fluid supply. Remove, clean, inspect foot valve. Clean filters or tip. Clean and inspect pump ball check valve.

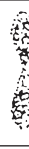
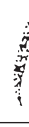
## Troubleshooting - Spray Patterns

Condition	Possible Cause	Correction
A. Tails 	Inadequate fluid delivery.  Fluid not atomizing correctly.	Increase fluid pressure. Change to small tip orifice size. Reduce fluid viscosity. Reduce hose length.  Clean gun and filter(s). Reduce number of guns using pump.
B. Hour glass 	Inadequate fluid delivery.	Same as above.
C. Distorted 	Plugged or worn nozzle tip.	Clean or replace nozzle tip.
D. Pattern expanding and contracting (surge) 	Suction leak. Pulsating fluid delivery.	Inspect for siphon hose leak. Change to a smaller tip orifice size. Install pulsation dampener in system or drain existing one. Reduce number of guns using pump.  Remove restrictions in system, clean tip screen if filter is used.
E. Round pattern. 	Worn tip. Fluid too heavy for tip.	Replace tip. Increase pressure. Thin material. Change nozzle tip.

## Troubleshooting - Hydraulic Motors

Condition	Possible Cause	Correction
A. Oil motor stalls at bottom (no unusual heat problems).	Fluid pump seat unthreaded.  Valve sticking or oil motor trip rod shifter assembly separated.	If connecting rod is okay, remove cylinder head plug and pop valve down. Replace plug and start machine. If machine cycles up and stops at bottom again, then problem is piston seat on fluid pump. Check piston seat. Repair or replace as necessary. If piston seat is okay and problem does not change, check oil motor.  Remove valve and check for scratches and rough movement when sliding it up and down. Replace valve and spool in this condition. Check trip rod for possible separation.
B. Oil motor stops at top (no unusual heat problems).	Valve sticking  Broken spring retainer (valve rod assembly) Broken spring or valve rod Air in hydraulic motor  Air in fluid pump	Remove valve and check for scratches and rough movement when sliding it up and down. Replace valve and spool in this condition.  Replace valve rod assembly.  Replace valve rod assembly. Reset valve. Purge Air, generally accomplished by low pressure cycling of motor/pump assembly for 5–10 minutes. Check for causes of air introduction: <ul style="list-style-type: none"> <li>• Loose fittings in tank.</li> <li>• Loose fittings on hydraulic pump.</li> <li>• Loose hose connections.</li> <li>• Low oil in reservoir.</li> </ul> Stall at top can occur randomly when fluid pump picks up air. Reset valve. Avoid air in the fluid pump.
C. Low pressure (okay on down stroke, sluggish on up stroke - high heat)  <b>NOTE: Engine labors on upstroke, idles back at stall on the down stroke.</b>	Blown piston seal  Cracked piston	Before dismantling oil motor, start machine. With pump cycling under pressure, touch the hydraulic cylinder and the head to see if cylinder or head gets hotter. This will help determine if piston seal is blown or piston nut is broken. If heat is on the head, check the o-rings on spool valve.  Dismantle oil motor and check piston seals cylinder bore and piston nut. Pay special attention to piston nut. It can be cracked and not show externally.
D. Low pressure (both strokes - high heat)  <b>NOTE: Engine labors at stall on both strokes.</b>	Blown center o-rings on spool valve  Bad hydraulic pump	Before dismantling oil motor, start machine. With pump cycling under pressure, touch the head to see if the head becomes hotter. This will help determine if center o-ring is blown on spool valve. If hot, remove and replace o-ring.  Replace hydraulic pump.

## Troubleshooting - Fluid Sections

Condition	Possible Cause	Correction
A. Pump delivers on upstroke only or goes up slowly and down fast (commonly called downstroke dive).	<p>Lower foot valve ball is not seating due to trash or wear.</p> <p>Material too viscous to siphon.</p> <p>Air leaking in on siphon side or damaged siphon hose. Siphon may be too small for heavy material.</p>	<p>Remove foot valve assembly. Clean and inspect. Test foot valve by filling with water. If ball fails to seal the seat, replace ball.</p> <p>Thin material - contact manufacturer for proper thinning procedures.</p> <p>Tighten all connections between pump and paint container. If damaged, replace. Switch to bigger siphon set.</p>
B. Pump delivers on down stroke only or goes up fast and down slowly.	<p>Upper ball is not seating due to trash or wear.</p> <p>Lower packing set is worn.</p>	<p>Check upper seat and ball with water. If ball fails to seal seat, replace.</p> <p>Replace packing set if worn.</p>
C. Pump moves up and down fast, not delivering material.	<p>Material container is empty or material is too thick to flow through the siphon hose.</p> <p>Bottom ball stuck to foot valve seat.</p> <p>Siphon hose is kinked or loose.</p>	<p>Refill with new material. If too thick, remove siphon hose and immerse pump or add thinner to material. Change to bigger siphon set. Open bleed valve to remove air and restart pump.</p> <p>Remove foot valve. Clean ball and seat. Straighten.</p>
D. Pump moves up and down slowly when spray gun is shut off.	<p>Loose connections. Bleed valve is open partially or bleed valve is worn. Lower packing set is worn.</p> <p>Upper and/or lower ball not seating.</p>	<p>Check all connections between pump and gun. Tighten as necessary. If material is flowing from bleed hose, close bleed valve or replace if necessary. Should none of above be evident, replace lower packing.</p> <p>Reset balls by cleaning.</p>
E. Not enough fluid pressure at gun.	<p>Spray tip is worn.</p> <p>Outlet filter or gun filter is clogged.</p> <p>Low voltage and/or inadequate amperage.</p> <p>Hose size or length is too small or too long.</p>	<p>Replace.</p> <p>Clean or replace filter.</p> <p>Check electrical service. Correct as required.</p> <p>Increase hose size to minimize pressure drop through hose and/or reduce hose lengths.</p>
F. Pump chatters on up or down stroke	Solvent has caused upper packing to swell.	Replace packings.

# Hydra Pro IV™ Major Components

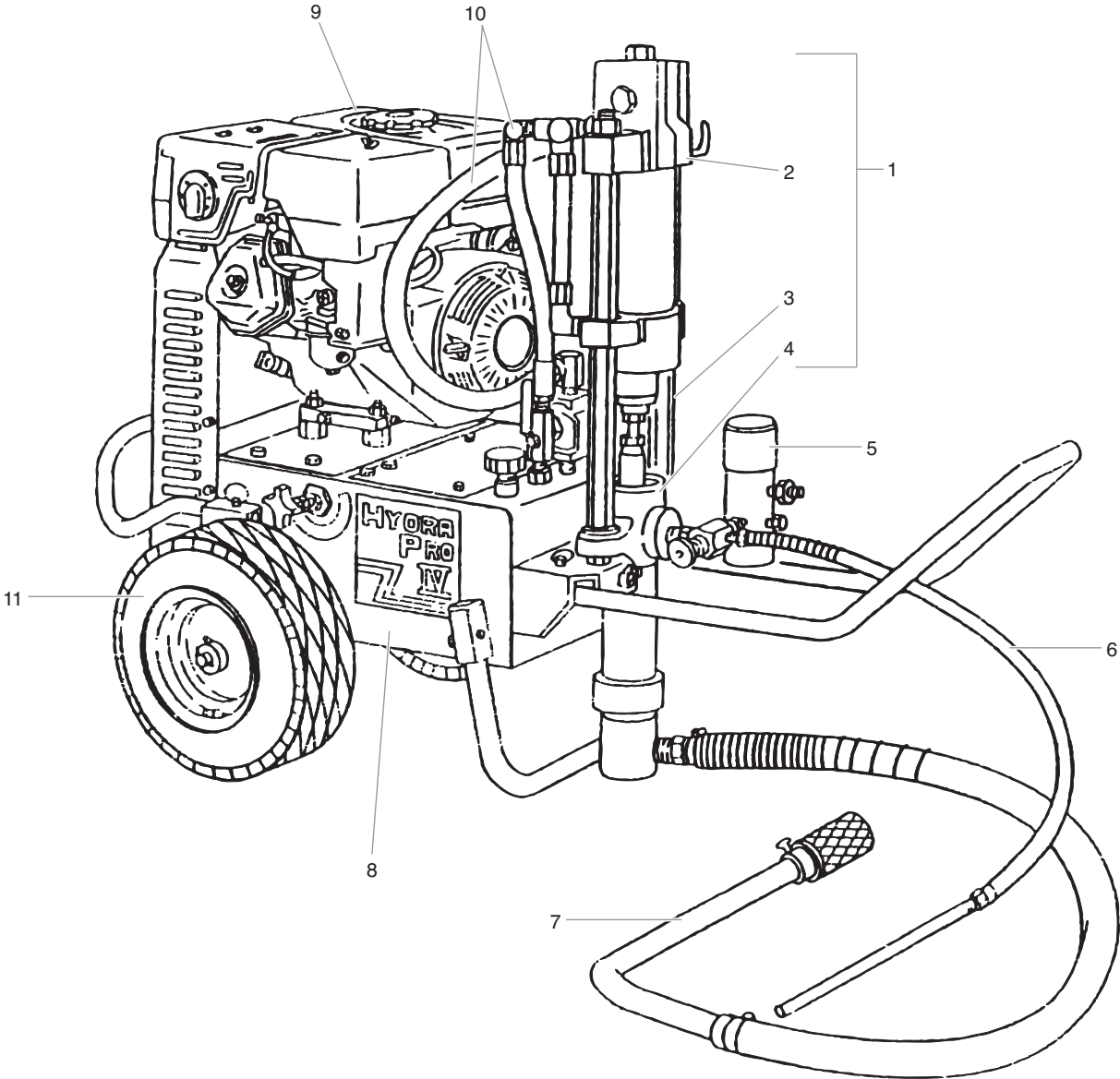

## Hydra Pro IV™ Major Components

ITEM NO.	PART NO.	DESCRIPTION	8 HP Honda
			Model # 433-820 422-821
1	441-185	Hydraulic motor pump assembly	1
2		441-574 Hydraulic motor assembly (1)	
3		441-101 Assembly set (1)	
4		185-551 Fluid pump assembly (1)	
5	920-559	Outlet manifold filter assembly, 50 mesh	1
6	840-209	Bleed line assembly w/valve	1
7	103-807	Siphon hose assembly, 1" x 4'	1
8	433-700	Tank assembly & hydraulic system	1
9	433-602	Engine / drive assembly, 8 HP Honda	1
10	432-689	Hydraulic hose set	1
11	590-311	MobilKit, standard	1

# Hydra Pro IV™ Hydraulic System

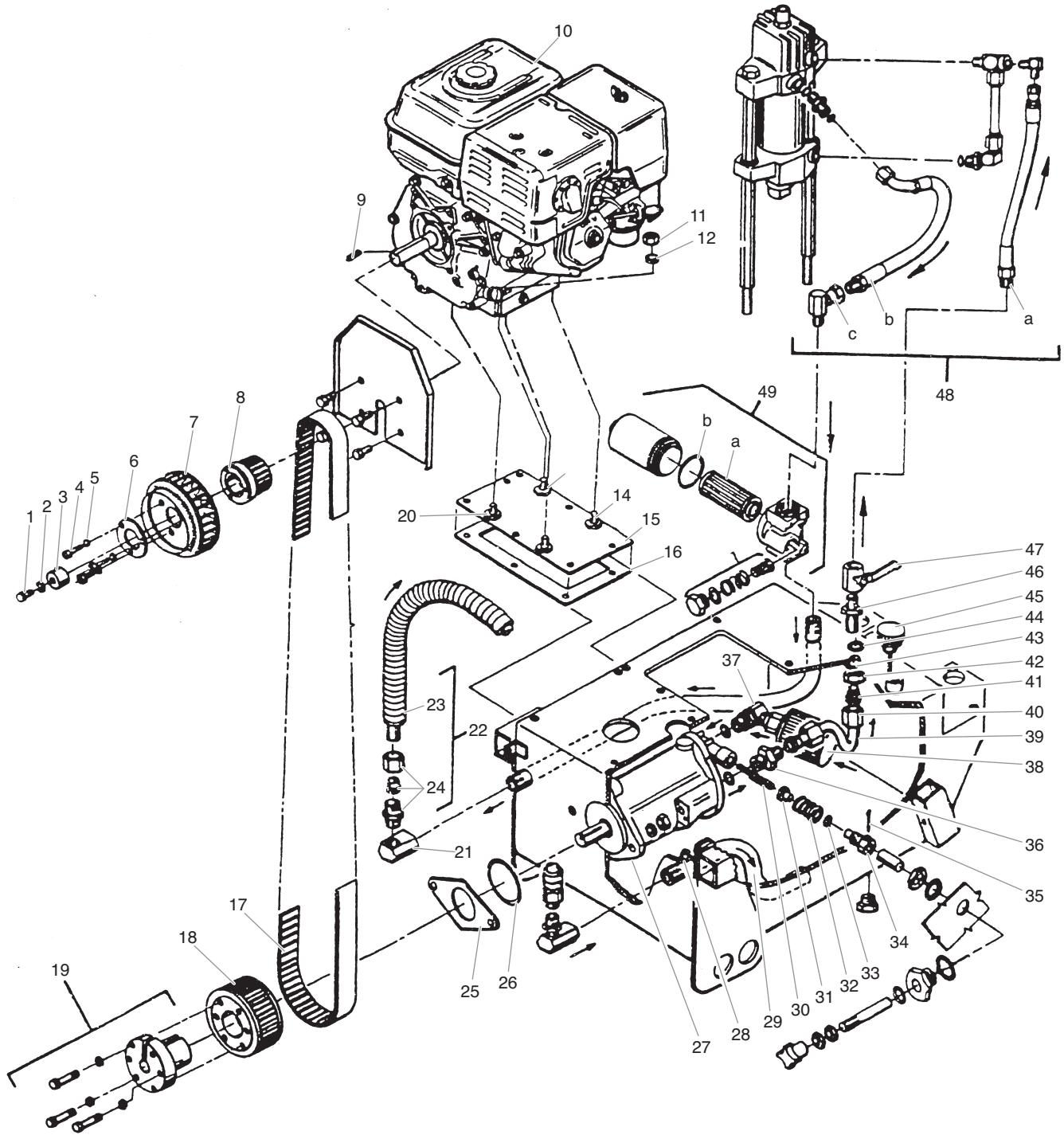



<b>Engine / Drive Assembly</b>			
<b>ITEM NO.</b>	<b>PART NO.</b>	<b>DESCRIPTION</b>	<b>QTY.</b>
1	864-639	Screw	1
2	864-002	Washer, lock	1
3	433-024	Sleeve	1
4	858-634	Screw	3
5	858-002	Washer, lock	3
6	432-646	Fan retainer ring	1
7	432-631	Fan	1
8	432-630	Pulley	1
9	980-308	Key	1
10	980-339	Engine, 8 HP Honda	1
11	860-501	Nut	4
12	860-002	Washer, lock	4
13	433-021	Pad, mounting	4
14	860-582	Screw	4
15	433-020	Plate, motor mount	1
16	434-652	Gasket	1
17	432-632	Belt, timing	1
18	416-330	Pulley	1
19	419-331	Pulley hub w/bolts	1
20	871-001	Shim	2

<b>Hydraulic System</b>			
<b>ITEM NO.</b>	<b>PART NO.</b>	<b>DESCRIPTION</b>	<b>QTY.</b>
21	433-683	Elbow	2
22	433-026	Heat exchanger assembly (includes items 23-24)	1
23	432-525	Heat exchanger	
24	432-613	Connector set (2)	
25	434-601	Gasket	1
26	432-601	O-ring	1
27	416-509	Pump	1
28	103-679	Clamp, hose	1
29	432-686	Hose, return	1
30	416-524	Spool	1
31	416-581	Button	1
32	416-588	Spring	1
33	416-226	O-ring	1
34	416-008	Stem, adjustment	1
35	185-983	Pin, cotter	1
36	441-206	Adapter / O-ring / nut	1
37	432-150	Elbow* swivel with nut	1
38	432-604	Filter, 100 mesh	1
39	432-676	Tube, pressure	1
40	432-645	Nut, tube	1
41	432-644	Ferrule	1
42	872-431	Nut	1
43	872-002	Washer, lock	1
44	872-005	Washer, nylon	1
45	335-010	Filter / dipstick	1
46	432-607	Adapter	1
47	940-557	Valve, ball	1
48	432-689	Hydraulic hose set	*
49	432-861	Filter assembly	1

\* Not included in this assembly

<b>#47 Hydraulic Hose Set Part No. 432-689</b>			
<b>ITEM NO.</b>	<b>PART NO.</b>	<b>DESCRIPTION</b>	<b>QTY.</b>
a	432-715	Pressure hose assembly	1
b	432-672	Return hose assembly	1
c	191-664	Swivel adapter	1

<b>#48 Filter Assembly Part No. 432-861</b>			
<b>ITEM NO.</b>	<b>PART NO.</b>	<b>DESCRIPTION</b>	<b>QTY.</b>
a	432-864	Element	1
b	432-863	O-ring	1

# Hydra Pro IV™ Tank Assembly and MobilKit

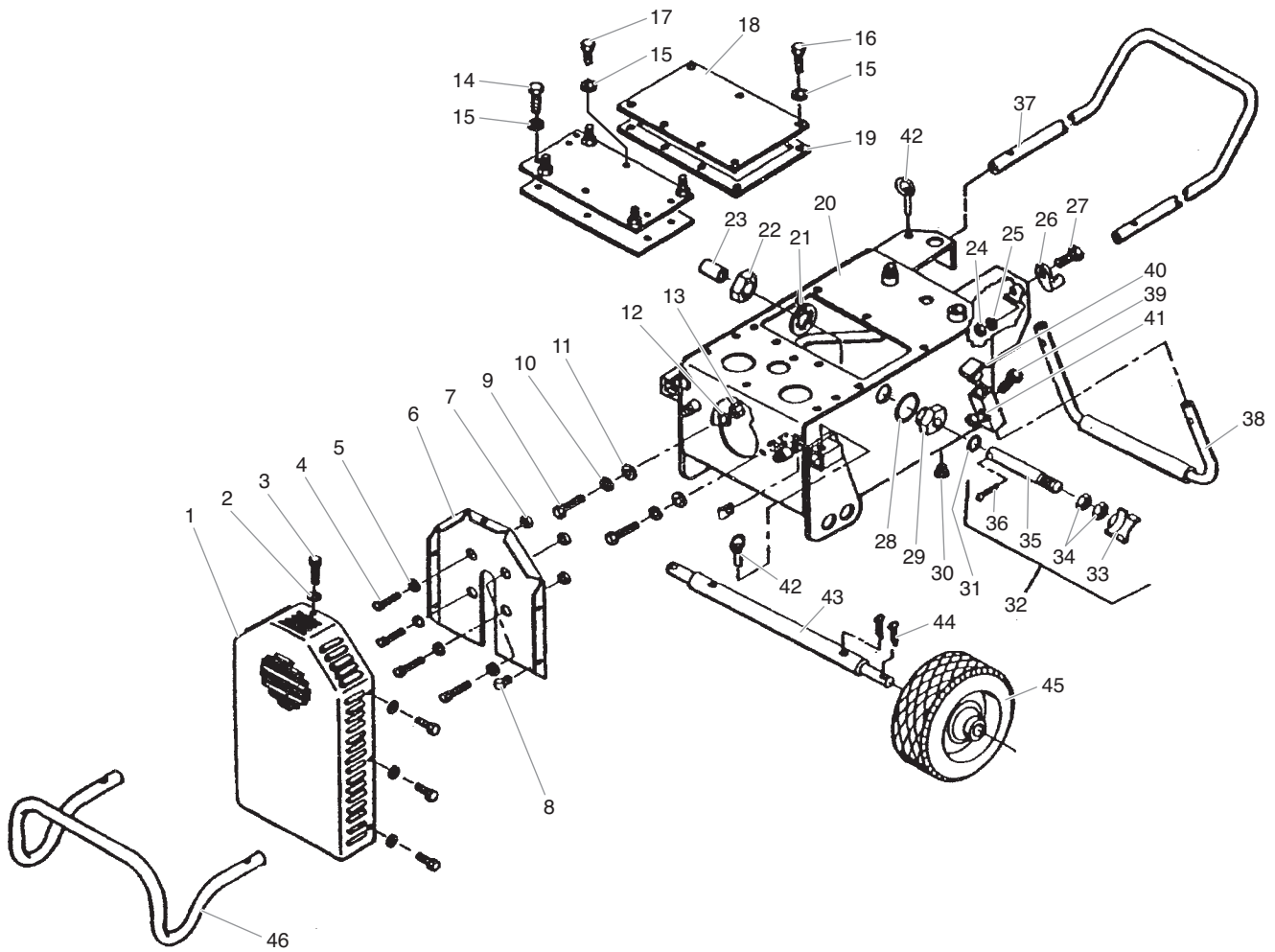

Tank Assembly & Hydraulic System			
ITEM NO.	PART NO.	DESCRIPTION	QTY.
1	434-662	Fan shroud	1
2	858-001	Washer	5
3	856-924	Screw	5
4	862-444	Screw	4
5	862-002	Washer, lock	4
6	434-661	Back plate	1
7	433-022	Spacer	4
8	856-963	Nut	5
9	862-452	Screw	2
10	862-001	Washer, flat	2
11	862-003	Washer, copper	2
12	862-002	Washer, lock	2
13	862-411	Nut, lock	2
14	860-528	Screw	6
15	860-002	Washer, lock	2
16	860-524	Screw, 5/16" - 18 x 5/8"	7
17*	860-524	Screw, 5/16" - 18 x 5/8"	1
18	434-676	Plate, inspection	1
19	434-677	Gasket, inspection plate	1
20	434-622	Tank	1
21	872-003	Washer, star	1
22	872-431	Nut, bulkhead	1
23	416-010	Sleeve	1
24	858-601	Nut	1
25	858-002	Washer, lock	1
26	101-205	Lug, ground	1
27	858-628	Screw	1
28	432-609	O-ring	1
29	434-621	Bushing	1
30	227-033	Plug, pipe	1
31	141-007	O-ring	1
32	434-682	Pressure control assembly	1
33	970-013	Knob	
34	866-601	Nut, jam (2)	
35	434-671	Shaft	
36	185-983	Pin, cotter	

Mobil Kit			
ITEM NO.	PART NO.	DESCRIPTION	QTY.
37	434-656	Handle	1
38	434-657	Foot	1
39	858-660	Screw	2
40	958-008	Cap, plastic	2
41	858-611	Nut	2
42	434-655	Pin, lock	4
43	435-641	Axle	1
44	570-010	Pin, cotter	4
45	670-109	Wheel	2
46	435-659	Bumper	1

\* Do not substitute with a longer screw.

# Hydra Pro IV™ 441-574 Hydraulic Motor

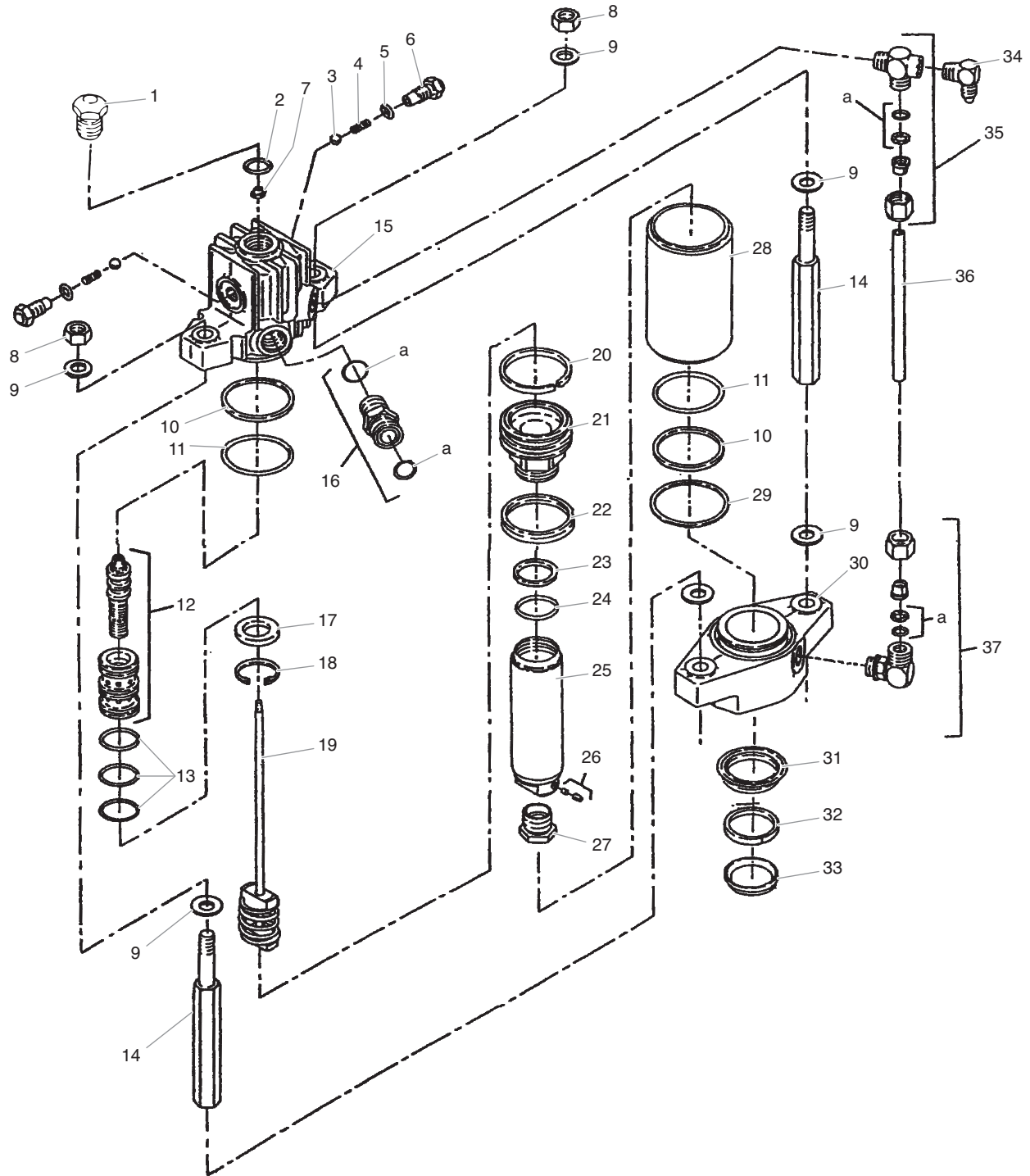

ITEM NO.	PART NO.	DESCRIPTION	QTY.
1	235-030	Plug, cylinder	1
2	441-217	O-ring	1
3	569-016	Ball	2
4	441-005	Spring, trip	2
5	141-007	O-ring	2
6	441-979	Retainer	2
7	858-811	Nut	1
8	870-401	Nut, stanchion	2
9	870-004	Washer, stanchion	6
10	441-149	Ring, back-up	2
11	441-148	O-ring	2
12	441-908	Valve spool/sleeve	1
13	441-152	O-ring	3
14	441-015	Stanchion	2
15	441-916	Head, cylinder	1
16	191-668	Adapter	1
16a	194-114	O-ring	
16b	194-113	O-ring	
17	441-211	Spacer	1
18	314-072	Ring, snap	1
19	441-377	Shifter actuator	1

ITEM NO.	PART NO.	DESCRIPTION	QTY.
20	441-238	Ring, wear	1
21	442-978	Piston	1
22	441-249	Seal, piston	1
23	441-026	O-ring	1
24	441-024	Ring, back-up	1
25	441-932	Piston tube	1
26	441-937	Set screw	1
27	431-007	Nut, coupling	1
28	441-312	Cylinder	1
29	441-151	Gasket, cushion	1
30	441-945	Base, motor	1
31	441-234	Seal, piston tube	1
32	445-237	Ring, wear	1
33	441-025	Wiper, piston tube	1
34	432-640	Elbow	1
35	441-017	Tee	1
35a	432-611	O-ring set	
36	441-789	Tube	1
37	432-729	Elbow	1
37a	632-611	O-ring set	

# Hydra Pro IV™ 441-574 Hydraulic Motor

## Service Instructions

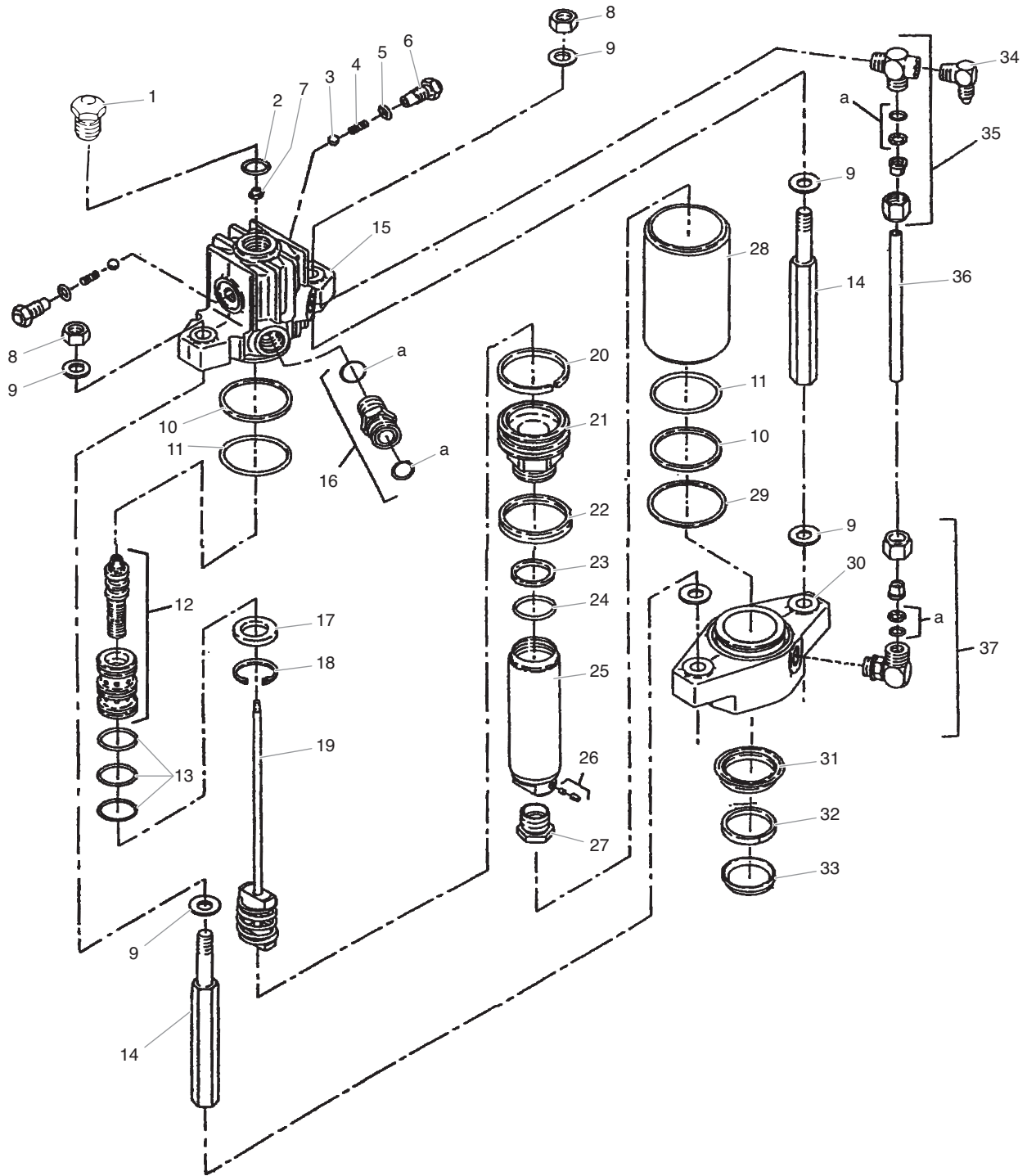

**IMPORTANT: Use of non-Titan manufactured service parts may void warranty. This motor contains hydraulic fluid. Take precautions to protect the immediate area from oil damage upon disassembly.**

**IMPORTANT: Disassemble this motor in a clean, dust free area. Any dust or dirt contamination of this assembly will shorten the service life of this motor and the hydrapac rotary pump.**

1. Release set screw (26) and remove coupling nut (27). Push out nylon button (26).
2. Remove cylinder plug (1) and O-ring (2).
3. Unthread connector nuts (35, 37) and release tube (36).
4. Unscrew upper stanchion nuts (8), remove washer (9).
5. Raise cylinder head (15) high enough to secure the shifter actuator rod (19) with vise grips. Place a socket wrench on the lock nut (7).
6. Unthread the lock nut (7).
7. Lift cylinder head (15) from upper motor stanchions (14). Remove O-ring (11) and back-up ring (10).
8. Carefully lift cylinder (28) and piston tube assembly (25) from motor base (30). Separate the cylinder and piston tube assembly. Remove O-ring (11) and back-up ring (10) from motor base. Remove cushion gasket (29).
9. Remove piston seal (22) and wear ring (20).
10. Remove piston tube seal (31), wear ring (32) and wiper (33) from motor base (30).

### Disassembly of cylinder head and shifter actuator rod

1. Remove trip retainers (6) along with O-rings (5), trip springs (4) and balls (3) from cylinder head (15).
2. Remove snap ring (18) with snap ring pliers.
3. Carefully lift out valve spool (12) with needle nose pliers.
4. Using a nylon rod or spool drive (P/N 990-009) from the top, push the valve sleeve (12) straight out of the cylinder head (15).
5. Place piston tube assembly (25) in horizontal position with bottom of assembly into heavy-duty vise.

**IMPORTANT: DO NOT mar chromed surface.**

Support the piston tube assembly (25) in the horizontal position with wood blocks and grip the flats of piston (21) with a 2 1/4" flat wrench to unthread piston.

### Reassembly

Wash all parts thoroughly with Coolflo™, part # 430-361. For routine servicing, use all new parts from Motor Service Kit, minor, part # 441-071.

For major overhaul, replace all parts contained in Motor Service Kit, major, part # 441-701. Inspect all other parts for abnormal wear or damage and replace if necessary.

1. Install new lower piston tube seal (31) in motor base (30). Install new O-ring (11) and new back-up ring (10) in motor base (30).
2. Slide piston tube assembly (25) into motor base from below.
3. Place new O-ring (23) and new back-up ring (24) onto piston (21).
4. Clean and coat the threads of the piston (21) with Loctite sealant, part # 426-051, and place shifter actuator assembly (19) with piston (21) into piston tube.

**IMPORTANT: DO NOT mar chromed surface.**

5. Place new piston seal (22) and new wear ring (20) on piston (21).
6. Push piston tube to the top of its stroke and place cylinder (28) over piston tube and seat the cylinder (28) on the motor base (30) over the new cushion gasket (29).
7. Push the valve sleeve and spool (12) straight into the cylinder head (15).

8. Place spacer (17) behind the valve sleeve and spool assembly (12).
9. Insert snap ring (18) to hold spacer (17) in place.
10. Place new O-ring (11) and new back-up ring (10) on cylinder head (15) and lower cylinder head on to cylinder (28), shifter actuator assembly (19) and upper stanchions (14) with washers (9).
11. Raise the cylinder head (15) to apply vise grips to the shifter actuator rod (19). Pass the shifter actuator rod through the valve spool (12). Clean and Loctite the shifter rod threads and install and tighten lock nut (3).
12. Thread cylinder plug (1) with new O-ring (2) into cylinder head (15), insert new balls (3), new springs (4), and replace trip retainers (6) together with new O-rings (5) into cylinder head (15).
13. Place stanchion nuts (8), washers (9) on upper stanchions (14). Tighten stanchion nuts (8) alternately.
14. Attach tube (36) to tee assembly (35) and elbow (37) by tightening connector nuts.

**NOTE: Areas where Loctite sealant is applied must be free of oil and grease.**

### Service Kits

Motor Service Kit, Minor Part No. 441-071			
ITEM NO.	PART NO.	DESCRIPTION	QTY.
2	441-217	O-ring	1
3	858-811	Nut	1
4	569-016	Ball, S.S.	2
5	441-005	Spring, trip	2
6	141-007	O-ring	2
10	441-149	Ring, back-up	2
11	441-148	O-ring	2
13	441-152	O-ring	3
20	441-238	Ring, wear	1
22	441-249	Seal, piston	1
23	441-026	O-ring	1
24	441-024	Ring, back-up	1
29	441-151	Gasket, cushion	1
31	441-234	Piston, tube seal	1
32	445-237	Ring, wear	1
	426-051	Loctite sealant	1

Motor Service Kit, Major Part No. 441-701			
ITEM NO.	PART NO.	DESCRIPTION	QTY.
	441-071	Motor service kit, minor	1
12	441-908	Valve spool / sleeve set	1
19	441-377	Shifter actuator assembly	1

# Hydra Pro IV™ 185-551 Fluid Pump Assembly

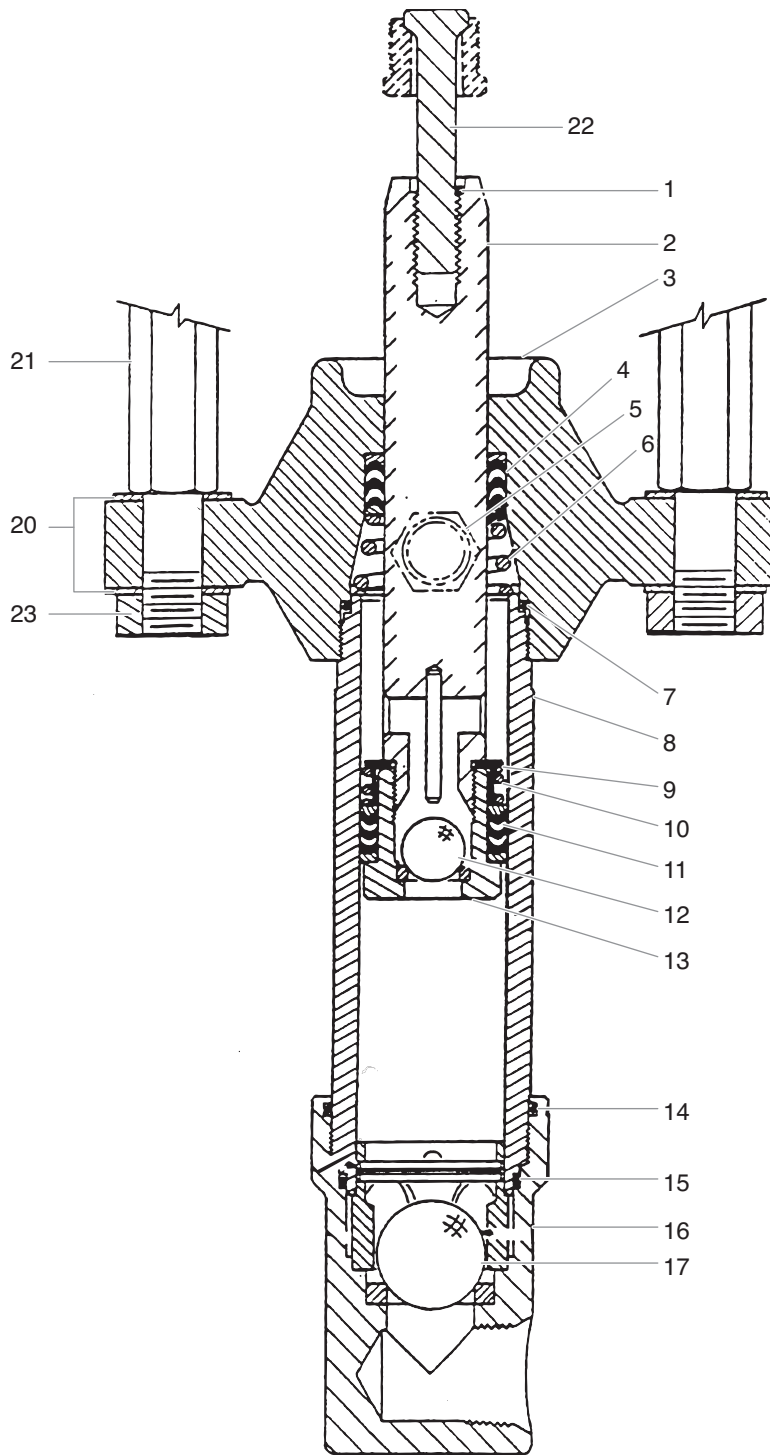

ITEM NO.	PART NO.	DESCRIPTION	QTY.
1	185-981	Pin, roll	1
2	185-984	Rod, displacement	1
3	181-906	Block, pump	1
4	178-001	Packing set, upper	1
5	228-002	Nipple, hex	1
6	182-906	Spring, packing	1
7	182-007	O-ring, PTFE	1
8	183-930	Cylinder	1
9	185-011	Retainer, spring	1
10	185-010	Spring, packing	1
11	180-001	Packing set, lower	1
12	920-103	Ball	1
13	182-921	Seat, piston	1
14	183-230	O-ring, Buna N	1
15	182-007	O-ring, PTFE	1
16	183-992	Valve, foot	1
17	314-180	Ball	1
18	240-022	Cage, ball	1
18a	241-109	Pin	1

Assembly Set - Part No. 441-101			
ITEM NO.	PART NO.	DESCRIPTION	QTY.
19	870-441	Nut	4
20	870-004	Washer	6
21	441-016	Stanchion	2
22	442-956	Rod, connecting	1

Displacement Rod Area		Stroke Length		Displacement Volume / Stroke			Displacement Volume / 40 Cycles / 80 Strokes				Motor Selection	Motor Pump ratio
IN <sup>2</sup>	CM <sup>2</sup>	IN	CM	IN <sup>3</sup>	CM <sup>3</sup>	LITER	IN <sup>3</sup>	GAL.	CM <sup>3</sup>	LITER	441 Series	3:1
1.38	8.90	4	10.2	5.55	90.9	0.091	444	1.92	7272	7.27		



## 185-551 Fluid Pump Service Information

**IMPORTANT: Use of non-Titan manufactured service parts may void warranty.**

The 185 Series Pump should receive a routine servicing after approximately 1000 hours of use or earlier if there is excessive leakage from the top packing, or if pump strokes become faster on one stroke or another. The use of Titan **Piston Lube Part # 314-480** is recommended as an upper packing lubricant. **DO NOT SUBSTITUTE OIL, WATER OR SOLVENT** for an upper packing lubricant.

### Disassembly Procedure

1. Test pump before disassembly. Follow test procedure in Troubleshooting Guide - Fluid Section.
2. Remove siphon hose assembly.
3. Remove stanchion nuts (19) and washers (20).
4. Hold the air motor piston rod at the wrench flats and unthread coupling nut to separate pump from motor.

**IMPORTANT: Never use a pipe wrench, pliers, etc. on the chrome part of hydraulic, air or fluid section rod.**

5. Remove roll pin (1) or jam nut on connecting rod (22). Remove connecting rod (22) from displacement rod (2).
6. Unthread and remove foot valve (16).
7. Remove PTFE O-ring (15), Buna O-ring (14), ball cage assembly (18) and ball (17).
8. Remove cylinder (8).
9. Remove displacement rod (2).
10. Place piston seat (13) in a vise and use a wrench on the flats to remove the displacement rod (2) from the piston seat (13).
11. Remove lower packing set (11), spring (10), spring retainer (9) and ball (12).
12. Remove upper packing spring (6), packing set (4) and O-ring (7).
13. Clean and inspect all parts. Inspect displacement rod's (2) and cylinder's (8) chrome for grooves, dents or worn areas. Replace if hard chrome is damaged. Inspect valve seats and replace if cracked or worn.

### Reassembly Procedure

1. Insert upper packing set (4) into pump block (3)

**IMPORTANT: Peak of "V" packings must point upwards on reassembly.**

2. Insert upper spring (6); small end of spring must go toward the packing set.
3. Insert spring retainer (9).
4. Place new lower packing set (11) over piston seat (13).

**IMPORTANT: Peak of "V" must point downward on reassembly.**

5. Replace spring (10), spring retainer (9) and new ball (12) on piston seat (13).
6. Thread piston seat (13) back onto displacement rod (2).

**IMPORTANT: Use Loctite on clean threads.**

7. Insert displacement rod (2) assembly through upper packing set (4) in pump block (3).
8. Place new O-ring (7) on end of cylinder (8) and thread back into pump block (3).

**IMPORTANT: Lubricate all O-rings before assembly.**

9. Insert new ball (17), ball cage (18), and new Buna O-ring (14) into foot valve.

**NOTE: Ball cage pin (18a) to be in lower position unless pump is to be used for heavy block filler or roofing materials.**

10. Place new PTFE O-ring (15) on cylinder (8) and then install foot valve assembly (16)

**NOTE: It is not necessary to overtighten foot valve and cylinder into pump block. O-ring seals perform sealing function without excessive tightening. Full thread engagement is sufficient. The foot valve (16) may be rotated back up to 3/4 turn from full engagement for convenient hose position.**

11. Insert connecting rod (22) through coupling nut and thread connecting rod (22) into displacement rod (2).
12. Insert roll pin (1) into connecting rod (22).

For siphon hose attachment, it is critically important that the thread of the siphon hose fit snugly into the foot valve with the hose assembly couplings PTFE-taped and sealed to prevent air inlet leakage.

### Service Kits

**NOTE: Minor service kit # 185-050 has polyethylene/leather packings.**

**Minor service kit # 180-051 has leather packings.**

**Minor service kit # 185-052 has PTFE packings.**

Pump service kit, minor			CTR	IND	TFL
ITEM NO.	PART NO.	DESCRIPTION	185-050	185-051	185-052
4	175-001	Packing set, upper		1	
4	178-001	Packing set, upper	1		
4	178-320	Packing set, upper			1
7	182-007	O-ring, PTFE	1	1	1
11	180-002	Packing set, lower		1	
11	180-322	Packing set, lower			1
11	183-001	Packing set, lower	1		
12	920-103	Ball	1	1	1
14	183-230	O-ring	1	1	1
15	182-007	O-ring, PTFE	1	1	1
17	314-180	Ball	1	1	1
	426-051	Loctite Sealant	1	1	1

Pump service kit, major			CTR	IND	TFL
ITEM NO.	PART NO.	DESCRIPTION	185-500	185-501	185-502
	185-050	Minor kit	1		
	185-051	Minor kit		1	
	185-052	Minor kit			1
2	185-984	Displacement rod	1	1	1
6	182-906	Spring, packing	1	1	1
8	183-930	Cylinder	1	1	1

# Hydra Pro IV™ Fluid Accessories

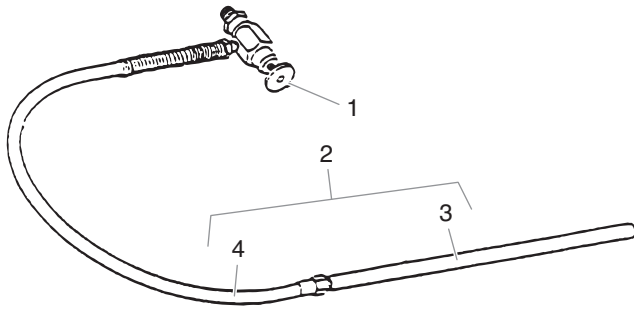

840-209 Bleed Line Assembly with Valve			
ITEM NO.	PART NO.	DESCRIPTION	QTY.
1	944-028	Valve, bleed	1
2	103-101	Bleed line assembly	1
3	103-117	Tube	
4	538-030	Hose assembly	

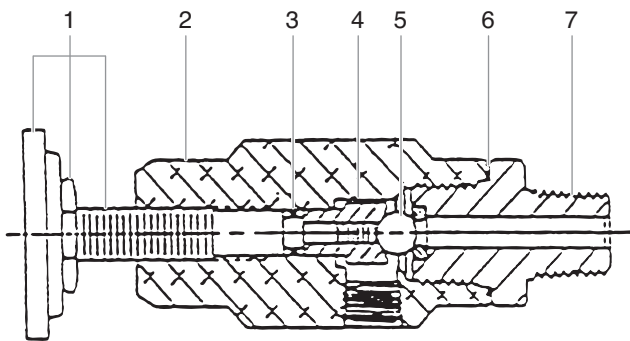

944-028 Bleed Valve Assembly			
ITEM NO.	PART NO.	DESCRIPTION	QTY.
1	944-024	Knob assembly	1
2	944-020	Valve body	1
3	944-004	O-ring	1
4	944-026	Valve stem stop	1
5	761-715	Ball, T.C.	1
6	945-003	Gasket, copper	1
7	944-904	Valve seat	1

## Service Instructions

The 944 Series Relief Valve has a tungsten carbide seat (9) and should not require frequent replacement. The tungsten carbide ball (7), in normal service, will last a long time because it rotates and wears evenly. If there is leakage, replace the ball.

**IMPORTANT:** Open the adjustment knob (1) to full counterclockwise position before unthreading valve seat (9) from valve body (4).

If the valve stem (3) is rotated inwardly with the ball removed, the PTFE O-ring (5) may require replacement. If there has been leakage from the valve stem, the PTFE O-ring should be replaced.

**IMPORTANT:** The valve stem stop (6) must be unthreaded from the valve stem (3) with a socket screwdriver, then the valve stem can be threaded out of the valve body.

**IMPORTANT:** All non-moving threads must be assembled with Loctite sealant, Titan part # 426-051.

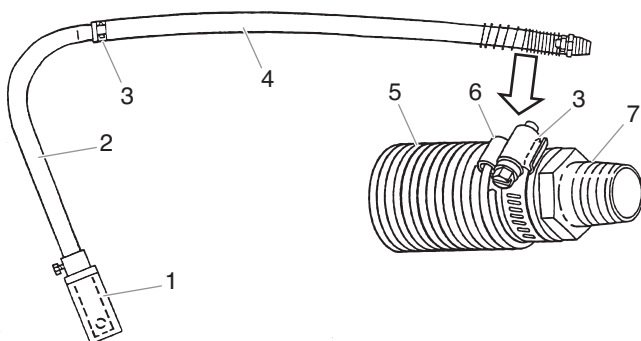

103-807 Siphon Valve Assembly 103-808 55 Gallon Siphon Assembly			
ITEM NO.	PART NO.	DESCRIPTION	QTY.
1	0509762A	Rock catcher	1
2	103-575	Tube	1
	103-585	Tube (55 gal. siphon ass'y)	1
3	103-679	Hose clamp	2
4	420-070	Hose	5'
5	103-125	Spring	1
6	103-119	Clip	1
7	0509760A	Adapter	1

# Hydra Pro IV™ Outlet Accessories

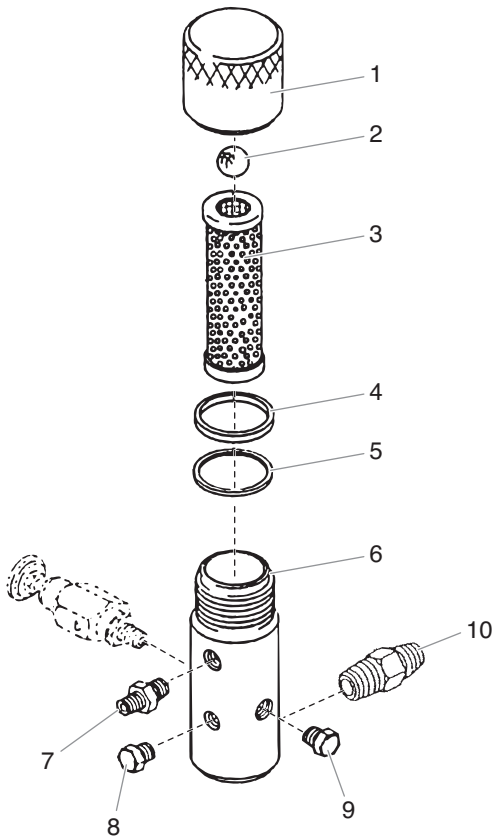

Outlet Manifold Filter Assembly Part No. 920-559			
ITEM NO.	PART NO.	DESCRIPTION	QTY
1	920-917	Filter cap assembly	1
2	920-103	Ball, S.S.	1
3	920-004	Screen, filter, 50 mesh	1
4	920-006	Gasket, PTFE (thick)	1
5	920-070	Gasket, PTFE (thin)	1
6	920-927	Body, filter (5000 psi)	1
7	812-003	Nipple, hex	1
8	227-027	Plug, pipe	1
9	227-033	Plug, pipe	1
10	703-137	Swivel fitting	1

Part No. 920-050 Filter Service Kit			
ITEM NO.	PART NO.	DESCRIPTION	QTY.
2	920-103	Ball	1
4	920-006	Gasket, PTFE	1
5	920-070	Gasket, PTFE	1

## Cleaning

Clean filter regularly. Dirty or clogged filters can greatly reduce filtering ability and cause a number of system problems including poor spray patterns, clogged spray tips, etc.

To clean the filter, shutoff system and relieve all system pressure. See the Pressure Relief Procedure on page 7.

1. Remove filter cap (1).
2. Pull filter element with check ball (3) straight out of the filter body (6).
3. Thoroughly clean inside filter body (6), filter element with check ball (3) and filter cap (1) with appropriate solvent. Use care in handling parts as dirt, debris, scratches or nicks may prevent O-rings or gaskets from sealing.

The 920 Series Filter Elements filter from the inside out. Be certain to clean the screen element thoroughly on the inside. Soak in solvent to loosen hardened paint, etc. or replace.

Specifications	
Max. Working Pressure	5000 psi (345 bar)
Filter Area	18in <sup>2</sup> (116 cm <sup>2</sup> )
Outlet Ports	(1) 1/4" NPT (F) for bleed valve (1) 3/8" NPT (F) with 1/4 NPSM (M) hose connection (1) 3/8" NPT (F) plug for additional gun hookup.
Wetted parts	Carbon steel with electroless nickel and cadmium plating, stainless steel, PTFE

# Hydra M™ & Hydra Pro Super™ Outlet Accessories - Gun Manifold Assemblies

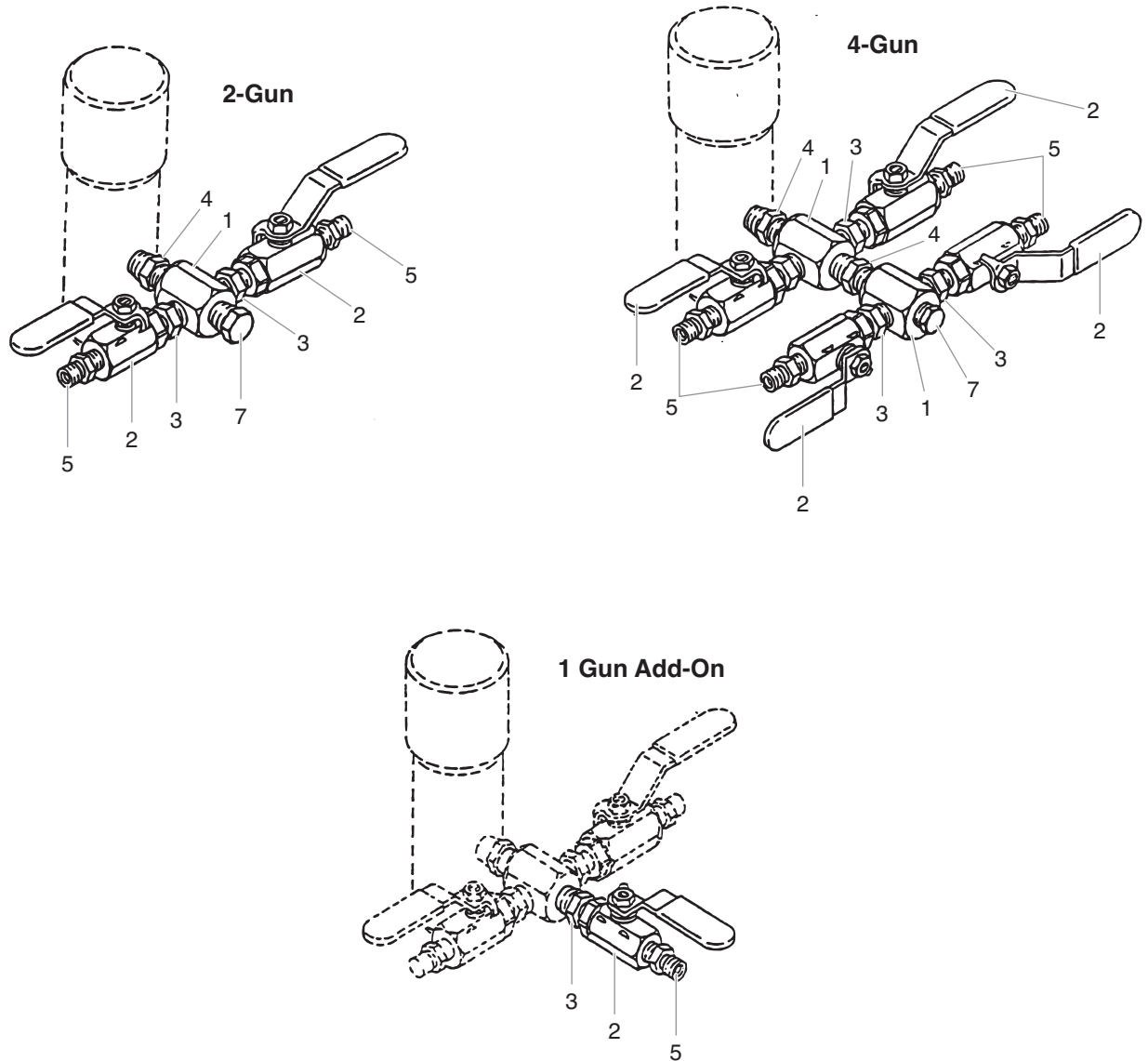

Gun Manifold Assemblies								
ITEM NO.	PART NO.	DESCRIPTION	975-212	975-214	975-111	975-302	975-304	975-311
			2 - GUN 1/4"	4 - GUN 1/4"	1 - GUN ADD-ON 1/4"	2 - GUN 3/8"	4 - GUN 3/8"	1 - GUN ADD-ON 3/8"
1	970-100	Manifold	1	2		1	2	
2	940-553	Valve, ball	2	4	1			
2a	941-555	Valve, ball				2	4	1
3	51551	Nipple, hex	2	4	1			
4	814-004	Nipple, hex	1	2		3	6	1
5	227-006	Nipple, hex	2	4	1			
6	808-555	Nipple, hex				2	4	1
7	227-033	Plug, pipe	1	1		1	1	

## Key Accessories and Service Kits

These items may be purchased separately from your local Titan distributor.

Part No.	Description
103-807	Siphon hose assembly with rock catcher 1" x 4' - 5 gallon
103-808	Siphon hose assembly with rock catcher 1" x 6 1/2' - 55 gallon
103-627	Rock catcher
920-001	Paint filter element, 5 mesh (for multicolors and heavy materials)
920-004	Paint filter element, 50 mesh (for latex and normal architectural materials)
920-005	Paint filter element, 100 mesh (for stains, lacquers and fine finish materials)
101-208	Grounding clamp
101-212	Grounding wire, 12 gauge x 25'
314-480	Piston Lube upper packing lubricant, 8 ounces
700-926	Piston Lube upper packing lubricant, 1 quart
430-362	Coolflo™ hydraulic fluid, 1 quart
430-361	Coolflo™ hydraulic fluid, 1 gallon
441-071	Minor service kit for hydraulic motor
441-701	Major service kit for hydraulic motor
185-050	Minor service kit for 185-551 fluid pump, polyethylene / leather packings
185-051	Minor service kit for 185-551 fluid pump, leather packings
185-052	Minor service kit for 185-551 fluid pump, PTFE packings
185-500	Major service kit for 185-551 fluid pump
920-050	Service kit for paint filter
944-050	Service kit for bleed valve
975-212	2-gun manifold with ball valves, 1/4"
975-214	4-gun manifold with ball valves, 1/4"
975-111	1-gun add-on, 1/4"
975-302	2-gun manifold with ball valves, 3/8"
975-304	4-gun manifold with ball valves, 3/8"
975-311	1-gun add-on, 3/8"

**Notes:**

**Notes:**

## Warranty

Titan Tool, Inc., ("Titan") warrants that at the time of delivery to the original purchaser for use ("End User"), the equipment covered by this warranty is free from defects in material and workmanship. With the exception of any special, limited, or extended warranty published by Titan, Titan's obligation under this warranty is limited to replacing or repairing without charge those parts which, to Titan's reasonable satisfaction, are shown to be defective within twelve (12) months after sale to the End User. This warranty applies only when the unit is installed and operated in accordance with the recommendations and instructions of Titan.

This warranty does not apply in the case of damage or wear caused by abrasion, corrosion or misuse, negligence, accident, faulty installation, substitution of non-Titan component parts, or tampering with the unit in a manner to impair normal operation.

Defective parts are to be returned to an authorized Titan sales/service outlet. All transportation charges, including return to the factory, if necessary, are to be borne and prepaid by the End User. Repaired or replaced equipment will be returned to the End User transportation prepaid.

THERE IS NO OTHER EXPRESS WARRANTY. TITAN HEREBY DISCLAIMS ANY AND ALL IMPLIED WARRANTIES INCLUDING, BUT NOT LIMITED TO, THOSE OF MERCHANTABILITY AND FITNESS FOR A PARTICULAR PURPOSE, TO THE EXTENT PERMITTED BY LAW. THE DURATION OF ANY IMPLIED WARRANTIES WHICH CANNOT BE DISCLAIMED IS LIMITED TO THE TIME PERIOD SPECIFIED IN THE EXPRESS WARRANTY. IN NO CASE SHALL TITAN LIABILITY EXCEED THE AMOUNT OF THE PURCHASE PRICE. LIABILITY FOR CONSEQUENTIAL, INCIDENTAL OR SPECIAL DAMAGES UNDER ANY AND ALL WARRANTIES IS EXCLUDED TO THE EXTENT PERMITTED BY LAW.

TITAN MAKES NO WARRANTY AND DISCLAIMS ALL IMPLIED WARRANTIES OF MERCHANTABILITY AND FITNESS FOR A PARTICULAR PURPOSE WITH RESPECT TO ACCESSORIES, EQUIPMENT, MATERIALS OR COMPONENTS SOLD BUT NOT MANUFACTURED BY TITAN. THOSE ITEMS SOLD, BUT NOT MANUFACTURED BY TITAN (SUCH AS GAS ENGINES, SWITCHES, HOSES, ETC.) ARE SUBJECT TO THE WARRANTY, IF ANY, OF THEIR MANUFACTURER. TITAN WILL PROVIDE THE PURCHASER WITH REASONABLE ASSISTANCE IN MAKING ANY CLAIM FOR BREACH OF THESE WARRANTIES.

Material Safety Data Sheets (MSDS) are available on Titan's website or by calling Customer Service.

**Register your product online at:**

**[www.titantool.com](http://www.titantool.com)**

Proper registration will serve as proof of purchase in the event your original receipt becomes misplaced or lost.

**Serial Number** \_ \_ \_ \_ \_



### United States Sales & Service

Phone: 1-800-526-5362

Fax: 1-800-528-4826

1770 Fernbrook Lane  
Minneapolis, MN 55447  
[www.titantool.com](http://www.titantool.com)

### Canadian Branch

Phone: 1-800-565-8665

Fax: 1-800-856-8496

200 Trowers Road, Unit 7B  
Woodbridge, Ontario L4L 5Z8

### International

Phone: 1-201-337-1240

Fax: 1-201-405-7449

1770 Fernbrook Lane  
Minneapolis, MN 55447